

**SONY.**

3-757-991-21(1)

# ***Compact Disc Player***

---

Operating Instructions



***CDP-315  
CDP-215***

# Warning

To prevent fire or shock hazard, do not expose the unit to rain or moisture.

To avoid electrical shock, do not open the cabinet. Refer servicing to qualified personnel only.

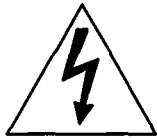
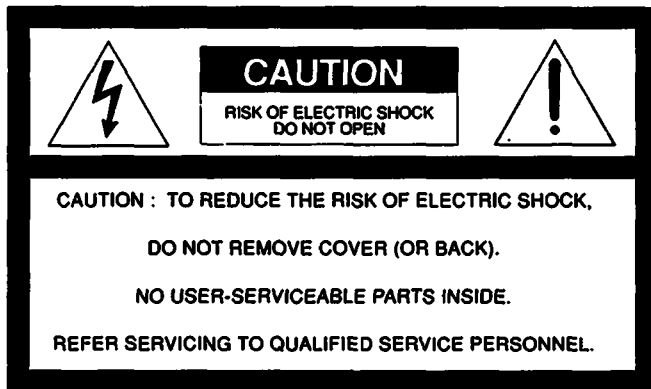

This symbol is intended to alert the user to the presence of uninsulated "dangerous voltage" within the product's enclosure that may be of sufficient magnitude to constitute a risk of electric shock to persons.



This symbol is intended to alert the user to the presence of important operating and maintenance (servicing) instructions in the literature accompanying the appliance.

## INFORMATION

This equipment has been tested and found to comply with the limits for a Class B digital device, pursuant to Part 15 of the FCC Rules. These limits are designed to provide reasonable protection against harmful interference in a residential installation. This equipment generates, uses, and can radiate radio frequency energy and, if not installed and used in accordance with the instructions, may cause harmful interference to radio communications. However, there is no guarantee that interference will not occur in a particular installation. If this equipment does cause harmful interference to radio or television reception, which can be determined by turning the equipment off and on, the user is encouraged to try to correct the interference by one or more of the following measures:

- Reorient or relocate the receiving antenna.
- Increase the separation between the equipment and receiver.
- Connect the equipment into an outlet on a circuit different from that to which the receiver is connected.
- Consult the dealer or an experienced radio/TV technician for help.

## CAUTION

You are cautioned that any change or modifications not expressly approved in this manual could void your authority to operate this equipment.

## Owner's Record

The model and serial numbers are located at the rear of the unit. Record the serial number in the space provided below. Refer to them whenever you call upon your Sony dealer regarding this product.

Model No. \_\_\_\_\_ Serial No. \_\_\_\_\_

# Table of Contents

## Chapter 1 Introduction

Safety precautions .....	3
Maintenance .....	3

## Chapter 2 Getting Started

Unpacking .....	4
Choosing a good location .....	4
Checking the supplied accessories .....	4
Inserting the batteries into the remote commander (only for CDP-315) .....	5
Hooking up the system .....	6
Notes on connection .....	6
Connecting to an equipment through digital output (only for CDP-315) .....	6
Identifying the parts .....	7
Front panel/remote commander .....	7

## Chapter 3 Basic Operations

Playing a disc .....	8
Playing the entire disc .....	8
Information display .....	9
Locating a particular selection .....	10
Locating a particular point in a selection .....	11
Fading in / fading out .....	11
Playing selections in a random order .....	12
Shuffle play .....	12
Playing in a desired order .....	13
Program play .....	13
Recording a program .....	14
Changing your program .....	15
Playing the beginning of each selection .....	16
Music scan play .....	16
Playing repeatedly .....	17
Repeat play .....	17

## Chapter 4 Advanced Operation

Designating the total playing time .....	18
Operating time edit .....	18
Fading out at the desired time - Time fade .....	20
Locating the portion with the highest level .....	21
- Peak search .....	21

## Chapter 5 Additional information

Specifications .....	22
Troubleshooting guide .....	23

### Convention



This indicates a function operated only on the main unit.

- As CDP-215 is not supplied with a remote commander, it does not have those functions activated only by remote commander.
- In the instructions starting from page 8, buttons on the remote commander are indicated in parenthesis, unless mentioned otherwise.

# Safety Precautions

Before operating the unit, please read the following precautions carefully.

**Check the operating voltage of the unit before operation.**  
Operate the unit only on 120 V AC, 60 Hz.

**Stop operation immediately if any liquid or solid object should fall into the cabinet.** Unplug the unit and have it checked by qualified personnel.

**Unplug the unit from the wall outlet if you do not use it for a long time.** Disconnect the cord by grasping the plug. Never pull the cord itself.

The unit is not disconnected from the AC power source (mains) as long as it is connected to the wall outlet, even if the unit itself has been turned off.

As the laser beam used in this unit is harmful to the eyes, do not attempt to disassemble the cabinet. Refer servicing to qualified personnel only.

The AC power cord must be changed only at a qualified service shop.

If you have any questions or problems concerning your unit, please contact your nearest Sony dealer.

For detailed safety precautions, see the leaflet "IMPORTANT SAFEGUARDS".

### Notes on handling discs

- To keep the disc clean, handle the disc by its edge. Do not touch the surface.
- Do not stick paper or tape on the disc.



- Do not expose the disc to direct sunlight or heat sources such as hot air ducts, nor leave it in a car parked in direct sunlight as there may be a considerable rise in the temperature.
- After playing, store the disc in its case.

### Caution on adjusting volume

Do not turn up the volume while listening to a portion with very low level inputs or no audio signals. If you do, the speakers may be damaged when a peak level portion is played.

## Maintenance

### Cleaning Your Unit

Clean the cabinet, panel and controls with a soft cloth lightly moistened with a mild detergent solution. Do not use any type of abrasive pad, scouring powder or solvent such as alcohol or benzene.

### Cleaning Discs

When a disc becomes dirty, clean it with a cleaning cloth. Wipe the disc from the center outwards.

Do not use solvents such as benzene, thinner, commercially available cleaners or anti-static spray intended for analog discs.



# Unpacking

## Choosing a Good Location

- Place the unit in a location with adequate air circulation to prevent internal heat build up in the unit
- Do not place the unit on a soft surface, such as a rug that might block the ventilation holes on the bottom.
- Do not install the unit:
  - near heat sources such as radiators or air ducts.
  - in a place subject to direct sunlight, excessive dust, mechanical vibration or shock.

## On moisture condensation

If the unit is brought directly from a cold to a warm location, or is placed in a very damp room, moisture may condense on the lens inside the unit. Should this occur, the unit will not operate. In this case, remove the disc and leave the unit turned on for about an hour until the moisture evaporates.

## Checking the Supplied Accessories

Make sure that all supplied accessories are included with your unit. This manual and the following items must be included with your unit.

If not, contact your Sony dealer.

- a) Audio connecting cord (1)
- b) Remote commander (1)  
(only for CDP-315)
- c) Sony SUM-3 (NS) batteries (2)  
(only for CDP-315)

Do not throw away the carton and the packing material. They will come in handy when transporting the unit or shipping it for servicing.

**A**

a)

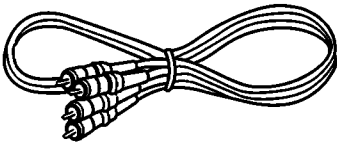

b)

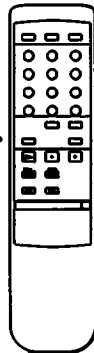

c)

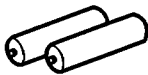

# Unpacking

## Inserting the Batteries into the Remote Commander (only for CDP-315)

You can control the unit with the supplied remote commander.

Insert two size AA (R6) batteries with the correct polarity.

**1 Slide the cover to remove it.**

**2 Insert two size AA (R6) batteries correctly so that the ⊕ and ⊖ polarities match the polarity diagrams inside the battery compartment.**

### On battery life

- About half a year of normal operation can be expected when using Sony SUM-3 (NS) batteries.
- When the batteries are run down, the remote commander will not operate the unit. If this happens, replace both batteries with new ones.

### Notes on the remote commander and remote control operation

- Keep the commander away from extremely hot or humid places.
- Avoid dropping any foreign objects into the commander casing, particularly when replacing the batteries.
- Avoid exposing the remote sensor to direct sunlight or lighting apparatus. Such exposure can cause a malfunction.
- To avoid damage caused by battery leakage and corrosion, remove the batteries when the commander will not be used for a long time.

1

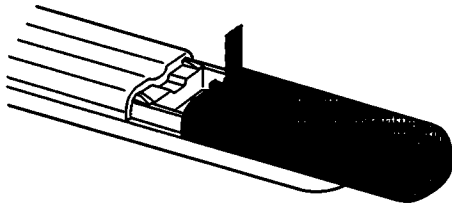

2

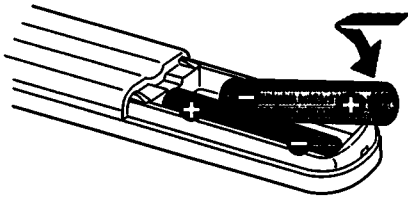

# Hooking Up the System

**A**

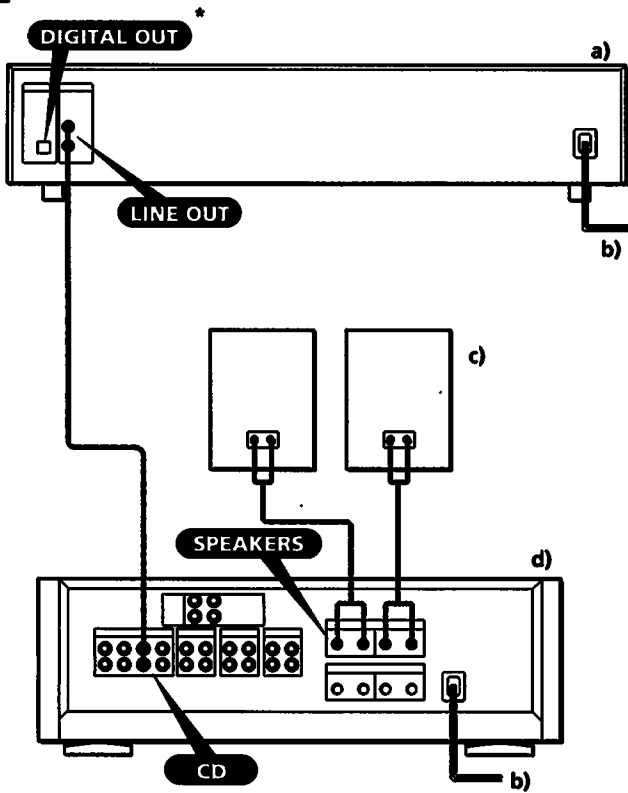

Connect the unit to an amplifier as shown in Fig. **A**.

- a) Compact disc player
- b) to an AC outlet
- c) Speakers
- d) Amplifier

## Notes on Connection

- Turn off the power of each unit before making connections. Connect the AC power cord last.
- Be sure to insert the plugs firmly into the jacks. Loose connection may cause hum and noise.
- Leave a little slack in the connecting cord to allow for inadvertent shock or vibration.
- The supplied audio cord plugs and jacks are color coded. Red plugs and jacks are for the right channel (R) and white ones for the left channel (L).

## Connecting to an Equipment through Digital Output (only for CDP-315) **B**

When connecting to an amplifier or to a D/A converter with the optical input jack, use the DIGITAL OUT (OPTICAL) jack instead of the LINE OUT jack. See the figure at the left.

Take off the cap and plug an audio optical connecting cord in firmly.

### Note on the DIGITAL OUT (OPTICAL) jack

When connecting with the DIGITAL OUT (OPTICAL) jack, use the POC-15 audio optical connecting cord (not supplied). Note that when the DIGITAL OUT (OPTICAL) jack is used, fade-in/fade-out and the time fade function cannot work. Moreover, you cannot adjust the DIGITAL OUT level with the PHONE LEVEL control. Also note that there may be some noise when you play a CD software other than music (such as a CD-ROM).

\* DIGITAL OUT (OPTICAL) jack is only supplied with CDP-315.

**B**



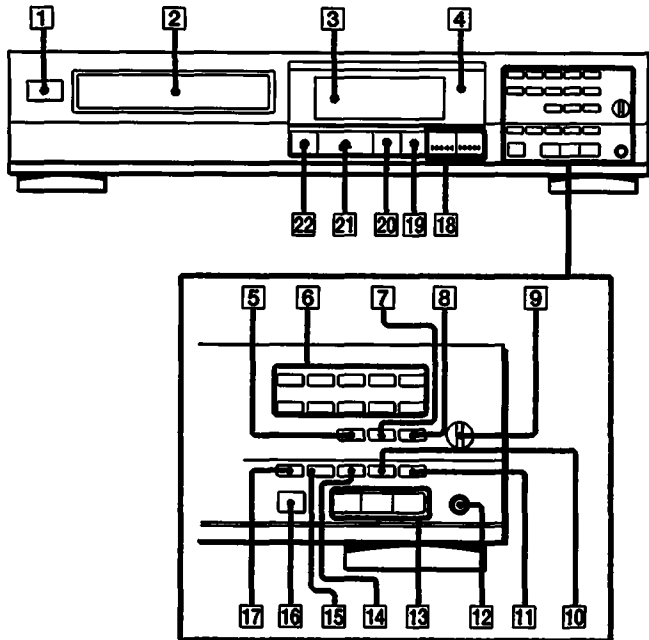

# Identifying the Parts

Refer to the pages indicated in parenthesis for details.

## Front Panel / Remote Commander

- 1 POWER switch (8)
- 2 Disc tray (8)
- 3 Display
- 4 Remote sensor
- 5 CHECK (program check) button (15)
- 6 Numeric buttons (10, 13, 14, 18, 20)
- 7 CLEAR (program clear) button (15)
- 8 >10 (over 10) button (10)
- 9 PHONE LEVEL control (8)
- 10 MUSIC SCAN button (16)
- 11 PEAK SEARCH button (21)
- 12 PHONES jack (8)
- 13 Play Mode buttons  
CONTINUE button (12, 13, 19)  
SHUFFLE button (12, 13, 19)  
PROGRAM button (13, 14)
- 14 FADER button (11)
- 15 REPEAT button (17)
- 16 EDIT/TIME FADE button (18, 19, 20)
- 17 TIME button (9)
- 18 <<<</>>>> (AMS\*/manual search) buttons (10, 11, 14, 16, 18, 20, 21)
- 19 ■ (stop) button (8)
- 20 ■■ (pause) button (8)
- 21 ▷ (play) button (8)
- 22 ▲ OPEN/CLOSE button (8)
- 23 <<</>>> (AMS\*) buttons (10, 14)  
(Only on the remote commander)
- 24 <<</>>> (manual search) (11, 16)  
(Only on the remote commander)

\* AMS is the abbreviation of Automatic Music Sensor.

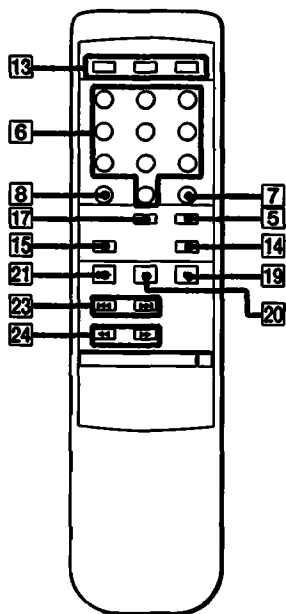

(only for CDP-315)

## Playing a Disc

In the continuous play mode, you can play from the first selection or desired selection on your disc.

Before playing a disc, turn on the amplifier and set the input selector to the CD player position.

### Playing the Entire Disc

**1 Press POWER.**

The display appears.

**2 Press  $\triangle$  OPEN/CLOSE.**

Place a disc with the printed side up on the tray.

**3 Press  $\triangleright$ .**

The disc tray closes and the first selection starts playing. The display shows you the following information.

- a) Selection number
- b) Elapsed playing time
- c) Music calendar

#### To stop play

To stop for a moment during play, press **||**.

To resume play, press  **$\triangleright$**  or **||** again.

To stop play, press **■**.

To stop play and open the tray, press  **$\triangle$  OPEN/CLOSE**.

#### For private listening

Connect a pair of headphones to the PHONES jack.

To increase the volume, turn the PHONE LEVEL control clockwise.

To decrease it, turn the control counterclockwise.

#### To take out the disc

Press  **$\triangle$  OPEN/CLOSE**.

#### To play an 8cm (3-inch) CD

Place it on the inner circle of the tray. If the disc is provided with an adaptor, first remove it. Do not put a normal CD (12cm/5 inch) upon an 8 cm CD.

1



2

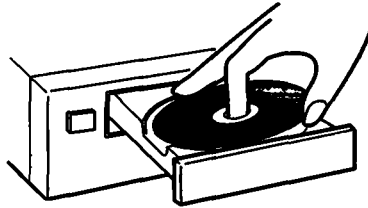

3

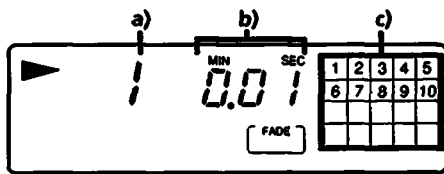



## Playing a Disc

### What is this indication?

*no disc*

This indication appears when there is no disc on the disc tray.

### If you turn on the power with a disc in the tray

Play begins automatically from the beginning of the disc. By connecting a commercially available timer, disc play can be started at any desired time.

## Information Display

### Figure A

When you press  $\Delta$  OPEN/CLOSE to close the tray, or press TIME in stop mode, the display shows you the following information:

The total number of selections (a) and the total playing time of the inserted disc (b)).

### Figure B

Each time you press TIME during play, the display changes to give you the following information:

- a) Elapsed playing time
  - b) Remaining time in a current selection
  - c) Remaining time of the disc
- However, "--. --" appears instead of the actual time when the remaining time exceeds 100 minutes in program mode.

### Note

The time display mode selected with TIME will not change until the power is turned off.

A

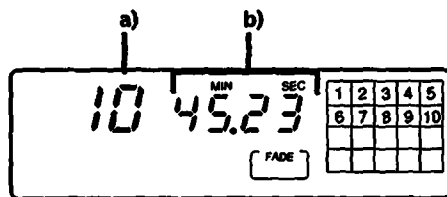

B

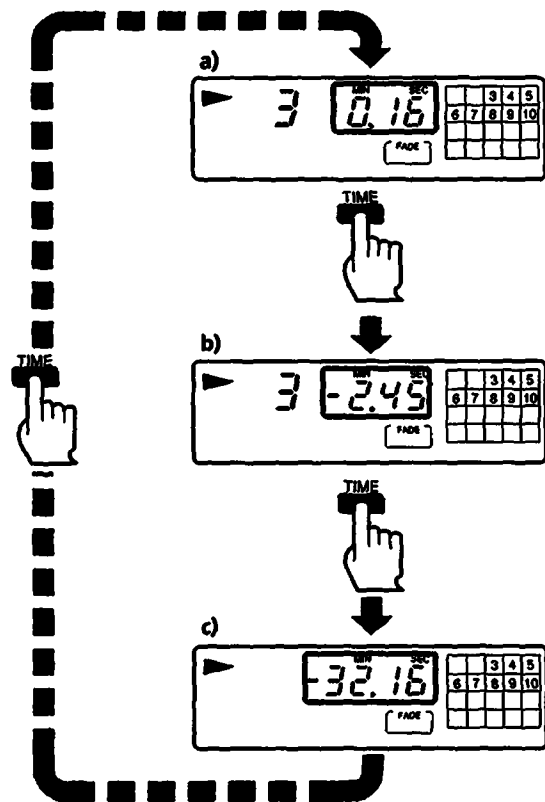

# Playing a Disc

## Locating a Particular Selection

You can locate the beginning of a desired selection in two ways.

### a) To locate sequentially

To locate the beginning of the current or preceding selection

- Press **⏮** (⏮) as many times as required.
- Keep **⏮** (⏮) pressed to skip selections in succession (Operable only in stop mode).

To locate the beginning of a succeeding selection

- Press **⏭** (⏭) as many times as required.
- Keep **⏭** (⏭) pressed to skip selections in succession (Operable only in stop mode).

### b) To locate directly

Press one of the numeric buttons to enter the desired selection number.

If a selection number is greater than 10, use the **>10** and **1** to **10** buttons.

**10** functions as the figure 0.

e.g. To play from selection No.22

Press **>10** and **2 2**.

e.g. To play from selection No.30

Press **>10** and **3 10**.

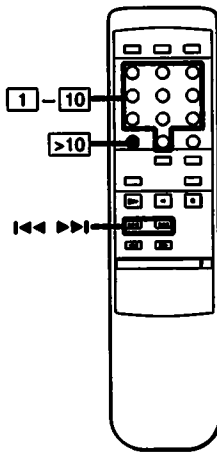
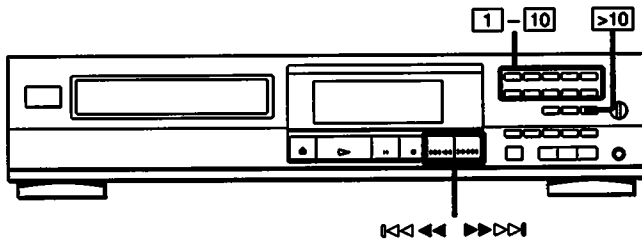

(only for CDP-315)



## Playing Selections in a Random Order

You can have all the selections played in a random order.

### Shuffle Play

#### 1 Press **SHUFFLE**.

"SHUFFLE" appears in the display.

#### 2 Press **▷**.

#### To cancel shuffle play

Press **CONTINUE** and the unit enters continuous play mode. "SHUFFLE" goes off from the display.

#### To check the remaining time

Press **TIME** once to see the remaining time of the selection being played, twice to see the total remaining time, and once more to return the initial display. (See page 9.)

#### To start shuffle play immediately from the current selection

Press **SHUFFLE** during play and shuffle play begins from the current selection.

#### On the displayed total playing time

A one-second access time blank is added between each selection. This increase is automatically added to the displayed total playing time.

#### What is this indication?



This indication appears while the unit is "shuffling" the selections.

1

SHUFFLE



2



# Playing in a Desired Order

You can make a program by designating up to 24 selections in desired order. The unit will play the disc according to your program.

## Program play

### 1 Press PROGRAM.

"PROGRAM" appears in the display.

### 2 Press the numeric buttons of the desired selections in desired order.

To select a selection number over 10, see page 10.

- a) Last programmed selection
- b) The order to be played
- c) Programmed selection numbers appear and then, after one second,
- d) The total playing time appears. (The total playing time will not appear when the total playing time exceeds 100 minutes.)

### If you choose wrong selections

Each time you press CLEAR, the last chosen selection is deleted.

### 3 Press ▷.

Program play starts.

### To stop playing

Press ■.

When you press ▷, you can play the same program repeatedly.

### To cancel program play

Press CONTINUE or SHUFFLE and the unit enters continuous or shuffle play mode respectively. The program will be erased.

### If you press PROGRAM during continuous or shuffle play

You can make a program by using the numeric buttons. The selection being played will be the first one in the program.

### On the displayed total playing time

Selections programmed consecutively but which are not numerically consecutive (i.e. 1, 3, 5, etc.) have a one second access time blank added between each one. This increase is automatically added to the displayed total playing time.

### What is this indication?

*FULL*

This indication appears if you try to add a selection to a program which contains 24 selections.

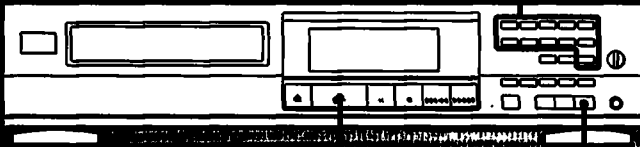

1

PROGRAM



2

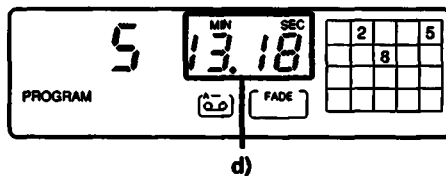
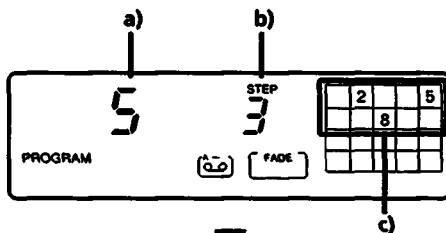
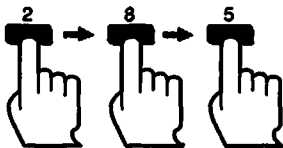

3



# Playing in a Desired Order

## Recording a Program

You can adjust the total playing time of the program, so that you can make the program fit the length of a tape when recording. Also the total playing time of program selection for side A and B can be adjusted, so that you can make two different programs for both sides of the tape when recording.

### 1 Press PROGRAM.

PROGRAM appears in the display.

### 2-A Press the numeric buttons of the desired selections in desired order. See page 13.

### 2-B To find selections which fit in the remaining time.

1) Press **⏪** **⏩** (**⏪**) or **⏩** **⏪** (**⏩**) to change a selection and check the time. - Program edit  
If satisfactory, go to the next step. If not, choose another selection.

### 2) Press PROGRAM to store the selection.

Step number appears in the display for a while. Repeat steps 1) and 2) to program other selections.

### 3 Press II to make a program for side B.

B appears in the tape indicator and "P" appears in the display, and the total playing time is reset to 0. A pause is also counted as a selection.

### 4 Program selections for side B by repeating step 2.

### 5 Start recording on the cassette deck and press ▷.

You had better start recording on the cassette deck first to transport the leader tape before pressing ▷ on this unit.

### To play the selections for side B

When the selections for side A are played, the unit enters pause mode. Reverse the tape, then press ▷ or II.

### To make a program only for one side of a tape

Follow the steps on page 13.

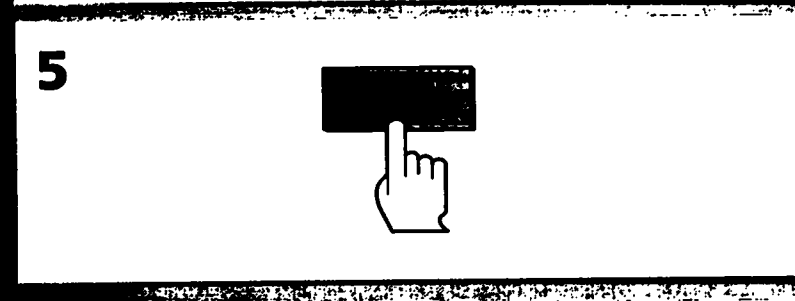
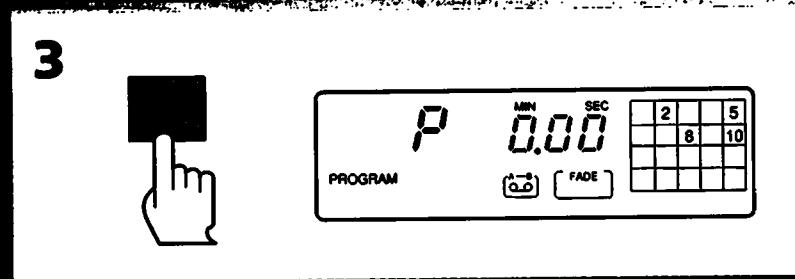
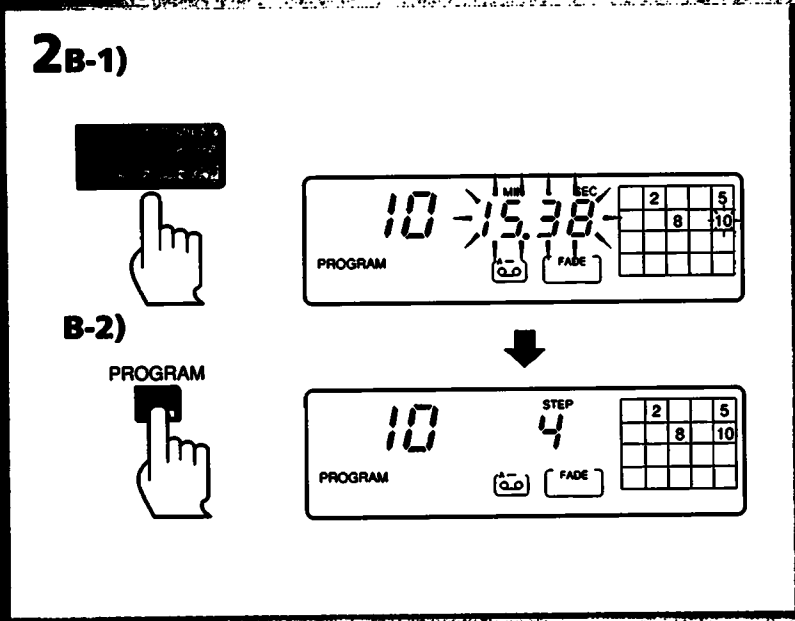
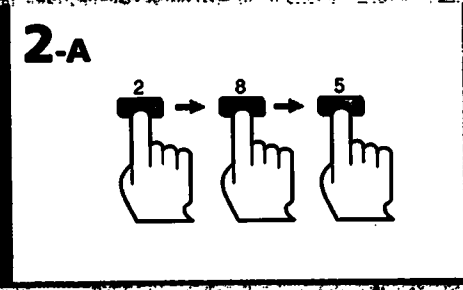
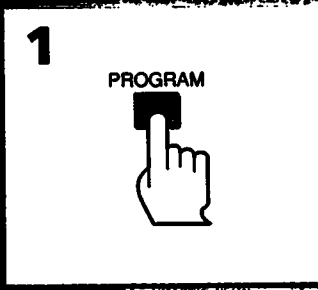
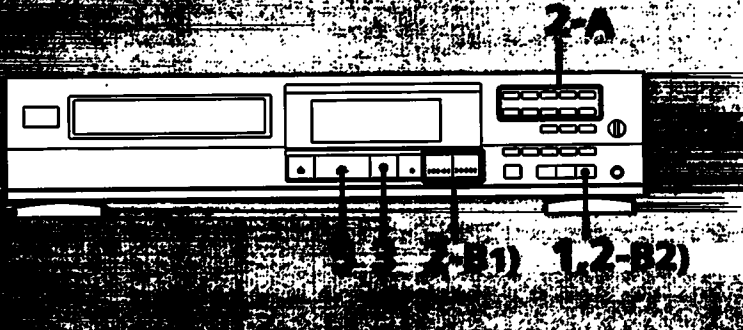

## Playing in a Desired Order

### To check your program

Press CHECK. The first selection in the program will appear.

Each time you press CHECK, the next selection in the program will appear. After the last selection, "End" will be indicated and the display will soon return to the initial status.

While checking the program for side A, (A) appears and also for side B, (B) appears.

### Changing Your Program

You can make the following changes before starting play.

**To erase the last selection,** press CLEAR.

Each time you press CLEAR, the last selection in the program will be erased.

**To erase the entire program**

Press ■ once in stop mode; twice during play. The program is also erased when you turn off the unit or you press OPEN/CLOSE.

**To add a selection to the end of the program,** simply press the numeric button.

**To delete a selection,** press CHECK repeatedly until the undesired selection appears. Then press CLEAR.

**To change the order,** press ■ in stop mode to erase the program. Then repeat the programming procedure from the beginning.

**To check the remaining time**

Press TIME once to see the remaining time of the selection being played; twice to see the total remaining time of the programmed selections; once more to return to the initial display.

If you have inserted a pause, the display shows the remaining time until the pause.

**What is the tape indicator?**

During program play, the tape indicator shows you which side of the program is being played.

(A) : Program A is being played.

(B) : Program A has been played and the unit is in pause mode, or program B is being played.

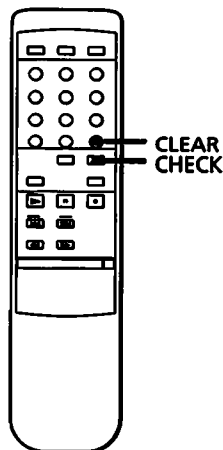
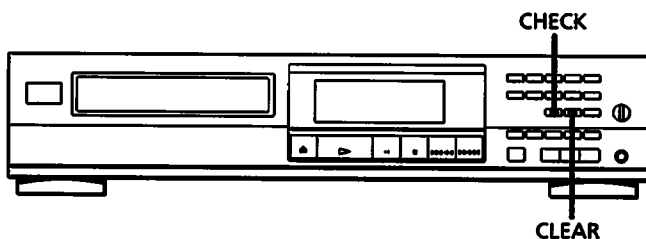

(only for CDP-315)

## Playing the Beginning of Each Selection



You can play the beginning of each selection consecutively in any play mode. It is useful for checking the contents of a disc or program. You can choose the playing time of each selection from among 10, 20 and 30 seconds.

This feature is operable during play as well as during stop.

### Music Scan Play

**Press MUSIC SCAN in stop or play mode.**

Each time you press MUSIC SCAN, the playing time of each selection changes cyclically from among 10, 20 and 30 seconds. The ► indication in the display flashes and the beginning of each selection is played for the designated period.

**To start normal play immediately during scanning**

Press ▷. The ► indicator in the display stops flashing.

**To change the designated playing time during scanning**

Press MUSIC SCAN consecutively within 1 second until the desired playing time appears in the display.

**If you keep ◀◀ (◀◀) or ▶▶ (▶▶) pressed**

Music scan play will be cancelled.

#### Note

Whenever the unit is turned off, scanning time is reset to 10 seconds.

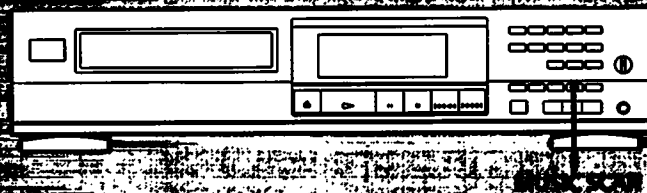

MUSIC SCAN

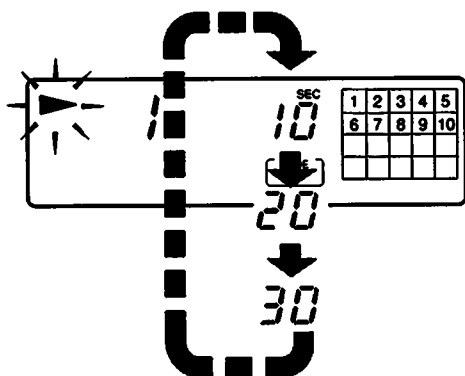



# Playing Repeatedly

You can choose between two different repeat play modes. One repeats all the selections in the current play mode, the other repeats any given selection.

## Repeat Play

### To repeat all selections a)

Press REPEAT once.  
The unit will repeat in the current play mode.

Play mode	Selections to be repeated
Continuous play	All the selections
Shuffle play	All the selections that the unit reshuffles
Program play	All the programmed selections in the same order

### To repeat the current playing selection b)

(only during continuous play)  
Press REPEAT again during repeat play, "REPEAT 1" appears.

### To cancel repeat play c)

Press REPEAT again.  
In continuous mode, "REPEAT 1" goes off.  
In shuffle and program play modes, "REPEAT" goes off.

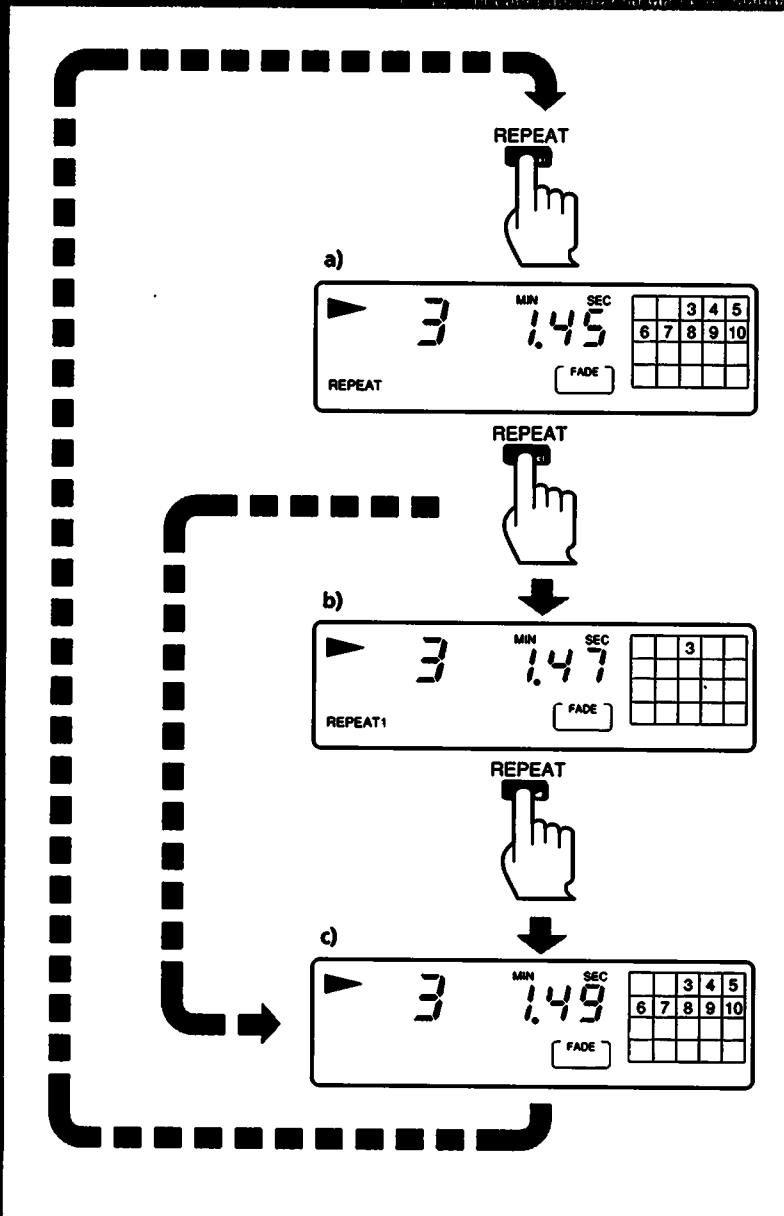

# Designating the Total Playing Time

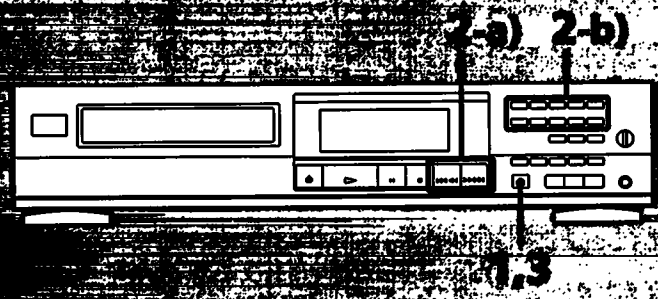

You can designate a playing time and the unit will make 2 different programs of selections each fitting within that period. These programs can contain up to a total of 24 selections. Use this function, by designating the length of your tape, for editing both sides of a tape. This function, called time edit, sets the playing time of each program within the designated time automatically, by choosing selections in numerical order which changes as little as possible.

You can also program desired selections by priority. In this case, you can designate desired selections beforehand and the remaining selections will be programmed to fit in the remaining time.

## Operating Time Edit

**1** Press EDIT/TIME FADE and display "EDIT"

**2** Designate the length of one side of your tape.

a) When you specify a commercially available tape length:

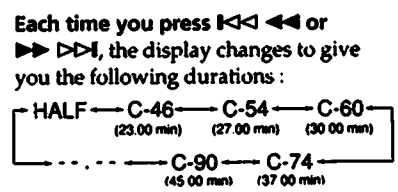

When you select HALF, dividing all the selections of the disc into two programs without changing their order.

b) When setting your desired time: Use the numeric buttons. Press [10] for "0". It is generally not necessary to press numeric buttons for seconds.

**HALF cannot be set in the following case:**  
 - a disc with more than 24 selections.  
 - when you have programmed desired selections beforehand.

**3** Press EDIT/TIME FADE. The selections for side A are determined automatically.

- a) The last selection to be recorded,
- b) Total playing time and
- c) Selections to be recorded on side A appear.

(to be continued)

**1**

EDIT/TIME FADE

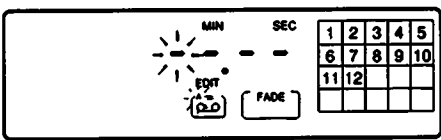

**2-a)**

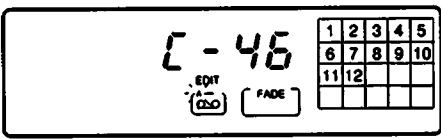
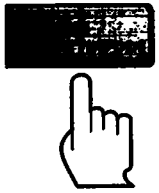

**b)**

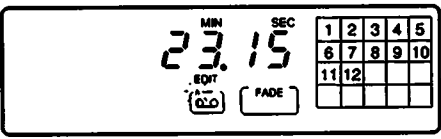
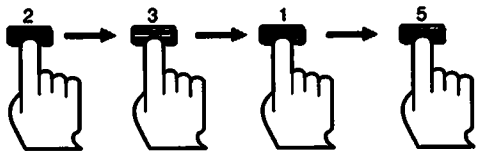

**3**

EDIT/TIME FADE

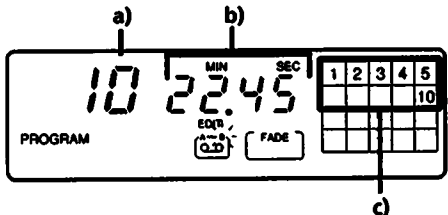

## Designating the Total Playing Time

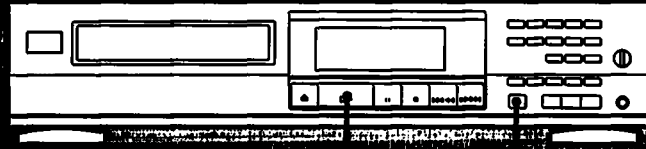

**5**

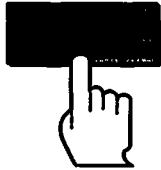

**4** Press **EDIT/TIME FADE** once more while "B" in the tape indicator is flashing.

Another program for the other side is completed.

**5** Press **▷**.

The selections for side A will be played and then the unit will pause. Reverse the tape, then press **▷** or **||** again. The selections for side B will be played.

### To cancel the edit

Press **CONTINUE** or **SHUFFLE** and the unit enters continuous or shuffle play mode respectively.

The program will be erased.

### To check the program

See page 15.

### To designate a different time for each side

Execute steps 1 to 3 on page 18, then press **||**. Then execute steps 2 to 3 for the other side.

### On the displayed total playing time

Selections programmed consecutively but which are not numerically consecutive (i.e. 1, 3, 5, etc.) have a one-second access time blank added between each one. This increase is automatically added to the displayed total playing time.

### If your disc has more than 24 selections

Selections over number 24 cannot be programmed with the time edit function.

# Fading Out at the Desired Time – Time Fade



You can end the play fading out by designating the play duration. Once the time fade is set, it functions twice for editing both sides of a tape. You can change discs without cancelling this function and use it in any play mode. Note that you cannot use the time fade function, when the DIGITAL OUT (OPTICAL) jack is used for connections. (CDP-315 only)

**1 Press EDIT/TIME FADE twice in stop mode, (or press it once in pause mode).**  
“TIME FADE” and “A” in the tape indicator displayed in the display.

**2 Press <<< or >>> to set the desired play duration.**

**a) When you specify a commercially available tape length:**

Each time you press <<< or >>>, the play duration for one side of the tape is displayed as follows.

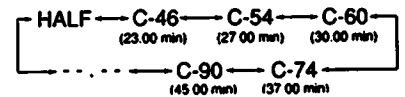

**When you select HALF**

The playing time of each program is set to a half of the total playing time of the disc.

**b) When setting the time for one side of the tape as you want:**  
Press the numeric buttons. Press [0] for “0”. It is generally not necessary to press numeric buttons for seconds, unless required.

**3 Press > to start playing.**

Before the unit enters pause mode at the set time with “B” lit in the tape indicator, play starts fading out.

**To start play for the other side of the tape**

Press > or II.

The unit enters pause mode at the set time by fading out for a specified duration. When this play ends, time fade is cancelled.

**1**

EDIT/TIME FADE

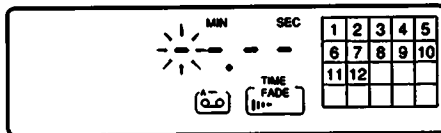

**2-a)**



**b)**

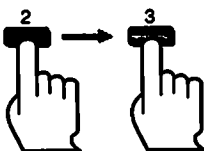

**3**

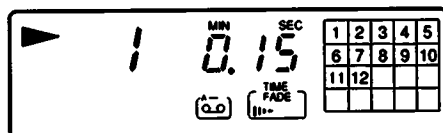

## Fading Out at the Desired Time – Time Fade



### To cancel time fade

Press EDIT/TIME FADE again.  
Time fade is also cancelled when  
◀◀ or ▶▶ is kept pressed.

### To display the time remaining until the set time

Press TIME twice.

### When play ends within the designated period

Time fade function is kept active. Change  
discs and start play. When the total playing  
time of the discs reaches the designated  
period, the unit pauses by fading out.

## Locating the Portion with the Highest Level – Peak Search



You can locate the portion with the highest  
input level of the disc to adjust the recording  
level.

Before starting play, press PEAK SEARCH.  
“PEAK” flashes in the display as the peak  
search begins functioning.

Upon completing the search, the unit starts  
repeating the portion with the peak volume  
so that you can adjust the recording level.

### To cancel the peak search

- Press ■. “PEAK” goes off from the display.
- Press || once to put the unit into pause mode at the beginning of the first selection.
- Press ▷ to start play from the first selection.

### On peak search

The unit scans input levels of the whole disc  
and determines the peak (maximum input  
level) among them. The peak determined  
with this function is sometimes slightly  
different from the real one. In addition,  
portions determined as a peak vary each  
time this function is carried out on the same  
disc. The difference between the determined  
and the real peak is, however, negligible and  
will not prevent you from adjusting the  
recording level.

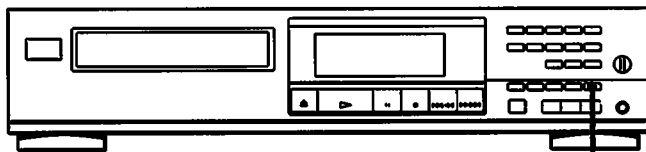

PEAK SEARCH

# Specifications

## Compact disc player

Laser	Semiconductor laser
Wavelength	780 - 790 nm
Frequency response	2 Hz to 20 kHz $\pm 0.5$ dB
Signal-to-noise ratio	More than 100 dB
Dynamic range	More than 98 dB
Harmonic distortion	Less than 0.0045%
Channel separation	More than 95 dB

## Outputs

LINE OUT (phono jacks)	Output level 2 V (at 50 kilohms) Load impedance over 10 kilohms
DIGITAL OUT (OPTICAL) (optical output connector) (only for CDP-315)	Wavelength 660 nm Output level -18dBm
PHONES (stereo phone jack)	Output level max. 10 mW Load impedance 32 ohms

## General

Power requirements	120 V AC, 60 Hz
Power consumption	10 W
Dimensions (approx., including projections)	430 x 100 x 295 mm (w/h/d) (17 x 4 x 11 $\frac{5}{8}$ inches)
Mass (approx.)	3.2 kg (7 lbs 1 oz)

## Remote commander (only for CDP-315)

Remote control system	Infrared control
Power requirements	3 VDC with two size AA (R6) batteries
Dimensions (approx., including projections)	44 x 21 x 185 mm (w/h/d) (1 $\frac{3}{4}$ x $\frac{7}{8}$ x 7 $\frac{3}{8}$ inches)
Mass (approx.)	100 g (4 oz)

## Supplied accessories

Audio cord	(1) (2 phono plugs - 2 phono plugs)
Remote commander (only for CDP-315)	(1)
Sony SUM-3 (NS) batteries (only for CDP-315)	(2)

Design and specifications are subject to change without notice.

# Troubleshooting Guide

Before going through the check list below, first refer back to the connections and operating procedures. Should any problem persist after you have made these checks, consult your nearest Sony service facility.

<b>Symptom</b>	<b>Cause</b>	<b>Remedy</b>
The disc tray does not close.	The disc is not placed correctly.	Place the disc correctly on the disc tray.
Play does not start.	Dirty disc.	Clean the disc.
	The disc is inserted upside down.	Insert the disc with the printed side up.
	A pause is engaged.	Press ▷ or    again to release it.
	Moisture condensation.	Leave the unit turned on for approximately one hour.
Sound is not heard.	Loose connection.	Insert the plug firmly.
	Connection is incorrect.	Check the connection referring to "Hooking Up the System".
	The PHONE LEVEL control is set to the minimum.	Turn the control clockwise.
Play does not begin from the first selection.	The unit is in the program or shuffle mode.	Press CONTINUE.
The remote commander does not operate the unit. (only for CDP-315)	The batteries are run down.	Replace both batteries.
	The remote commander is not pointed at the remote sensor.	Point the remote commander at the sensor.
	There is an obstacle between the remote commander and the unit.	Remove the obstacle.
	The remote commander is too far from the unit.	Move closer.